

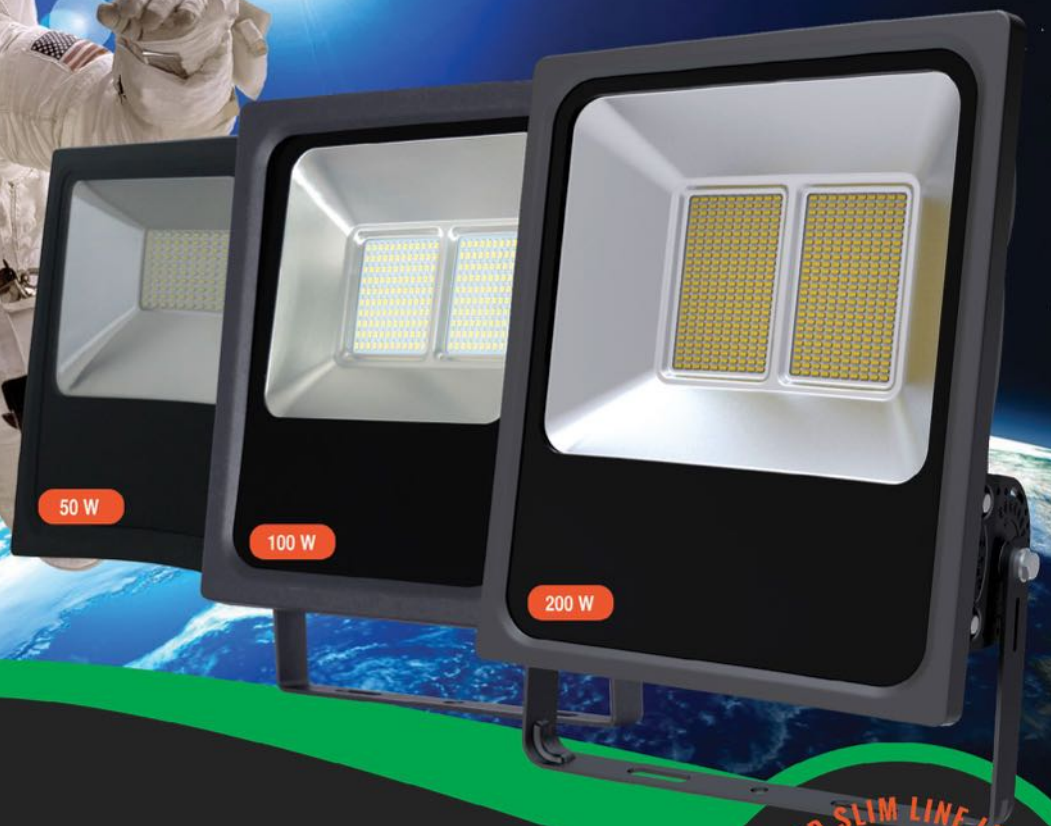

APOLLO

LED Flood Lighting

HIGH DEFINITION



Apollo Series Compact Design Flood lighting

Apollo Series compact design small form factor floodlight range in 50w, 100w and 200W models offer fully sealed IP65 water and dust protection. Using advanced surface mount LED design and thermal heat management giving superior lighting levels in a smaller more compact design.



LED flood lights are now the most efficient, reliable lighting source for security lighting and general illumination of commercial indoor and outdoor spaces. Low power consumption and maintenance free operation make them a perfect alternative to traditional outdoor lighting. LED flood lights also give exceptional light clarity with a wide beam angle and even light spread.

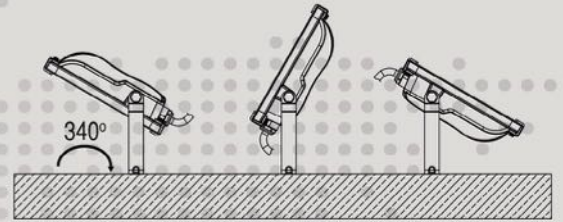

Can be rotated 340° horizontally and 360° vertically the APOLLO Series LED Flood Lighting is ideal for a variety applications and environments.

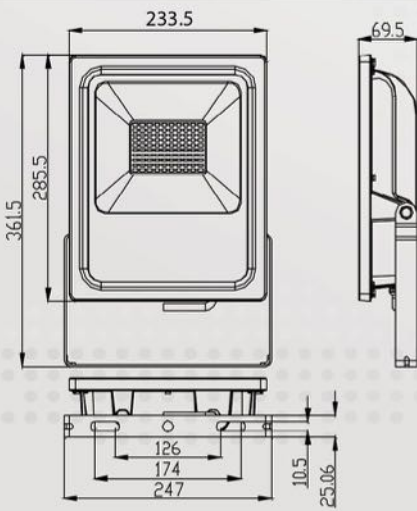

GFS-APOLLO-50

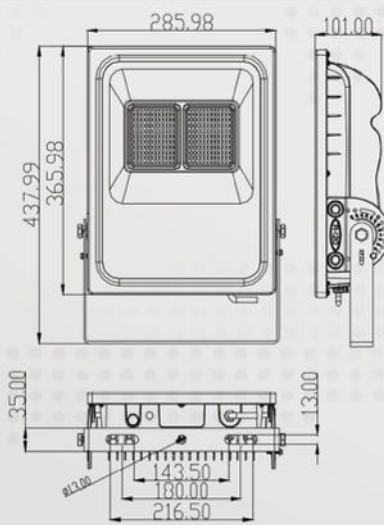

GFS-APOLLO-100

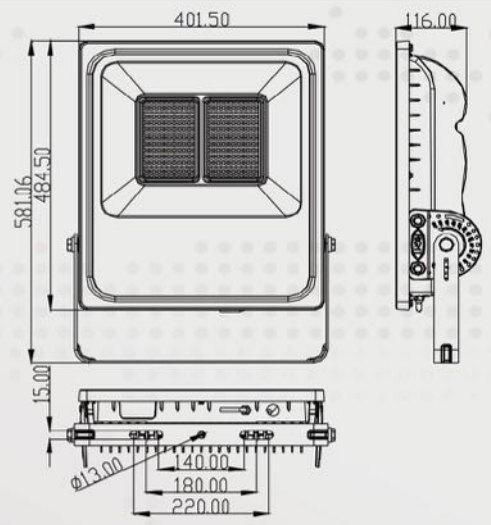

GFS-APOLLO-200

PRODUCT DETAILS		PHOTOELECTRIC SPECIFICATIONS				WEIGHT + DIMENSIONS			LIGHT SOURCE		ENVIRONMENT	
PART NUMBER	PRODUCT IMAGE	POWER	INPUT VOLTAGE FREQUENCY POWER FACTOR	LUMINOUS FLUX	BEAM ANGLE	WEIGHT	DIMENSIONS	PACKAGE SIZE	LED TYPE / COLOUR TEMP	COLOR ACCURACY (CRI)	OPERATING TEMP RANGE	OPERATING HUMIDITY RANGE
GFS-APOLLO-50		50W		4250Lm		2.54kg	L235*W69*H361	L305*W260*H95				
GFS-APOLLO-100		100W	AC 100-240V 50/60HZ PF > 0.9	8500Lm	120°	5.8kg	L285*W101*H438	L390*W330*H145	SMD5730 Cool White (5000-6500K)	CRI>70	-20~50°C	95% Rh or below (@-20°C~50°C) low (@-20°C~50°C)
GFS-APOLLO-200		200W		18000 Lm		10.9kg	L401*W116*H581	L490*W410*H180				

